

**Warranty Registration:**  
register online today for a chance  
to win a FREE Tripp Lite product—  
[www.tripplite.com/warranty](http://www.tripplite.com/warranty)



# Owner's Manual

PowerVerter®

## DC-to-AC Inverter

Model: PV700HF

Input  
12V DC

Output  
120V, 60Hz AC



1111 W. 35th Street, Chicago, IL 60609 USA  
[www.tripplite.com/support](http://www.tripplite.com/support)

### Reliable AC Power Wherever You Need It

Congratulations! You've purchased a high-quality Inverter designed to function as a mobile energy source powered by your automotive battery. PowerVerter Inverters convert 12V DC (battery) power into 120V AC (household) power, allowing you to use equipment you commonly use at home—computers, appliances, electronics, power tools and more—while traveling by automobile or working at remote locations that lack AC power. PowerVerter Inverters include advanced features that protect your equipment, lengthen the service life of your battery and ensure that you'll always have battery power to start your vehicle:

- Automatic Overload Protection
- Automatic Low Battery Protection
- High-Performance DC-to-AC Inversion
- Frequency-Controlled Output Power
- Simple, Maintenance-Free Operation
- Moisture-Resistant Construction\*
- 3 AC Outlets

\* The inverter is moisture-resistant, not waterproof.

## Contents

<b>Important Safety Instructions</b>	<b>2</b>
<b>Feature Identification</b>	<b>3</b>
<b>Operation</b>	<b>3</b>
<b>Battery Selection</b>	<b>3</b>
<b>Mounting</b>	<b>4</b>
<b>Battery Connection</b>	<b>4</b>
<b>Service</b>	<b>5</b>
<b>Maintenance/Troubleshooting</b>	<b>6</b>
<b>Specifications</b>	<b>6</b>
<b>Limited Warranty and Warranty Registration</b>	<b>6</b>
<b>Español</b>	<b>7</b>
<b>Français</b>	<b>14</b>



## SAVE THESE INSTRUCTIONS!

This manual contains important instructions and warnings that should be followed during the installation, operation and storage of all Tripp Lite Inverters.

### Location Warnings

- Install your Inverter (whether for a mobile or stationary application) in a location or compartment that minimizes exposure to heat, dust, direct sunlight and moisture.
- Although your Inverter is moisture resistant, it is NOT waterproof. Flooding the unit with water will cause it to short circuit and could cause personal injury due to electric shock. Never immerse the unit, and avoid any area where standing water might accumulate. Mounting should be in the driest location available.
- Leave a minimum of 2 inches (5 cm) clearance at front and back of the Inverter for proper ventilation. The heavier the load of connected equipment, the more heat will be generated by the unit. Any compartment that contains the Inverter must be properly ventilated with adequate outside airflow to avoid overheating the Inverter.
- Do not install the Inverter directly near magnetic storage media, as this may result in data corruption.
- Do not install near flammable materials, fuel or chemicals.
- **Do not mount unit with its front or rear panel facing down (at any angle). Mounting in this manner will seriously inhibit the unit's internal cooling, eventually causing product damage not covered under warranty.**

### Battery Connection Warnings

- Multiple battery systems must be comprised of batteries of identical voltage, age, amp-hour capacity and type.
- Because explosive hydrogen gas can accumulate near batteries if they are not kept well ventilated, your batteries should not be installed (whether for a mobile or stationary application) in a “dead air” compartment. Ideally, any compartment would have some ventilation to outside air.
- Sparks may result during final battery connection. Always observe proper polarity as batteries are connected.
- Do not allow objects to contact the two DC input terminals. Do not short or bridge these terminals together. Serious personal injury or property damage could result.
- Connect the Inverter to the battery with recommended DC fusing (see *Battery Connection*).

### Ground Connection Warnings

- Safe operation requires connecting the Inverter's main grounding screw directly to the frame of the vehicle or earth ground.

### Equipment Connection Warnings

**Use of this equipment in life support applications where failure of this equipment can reasonably be expected to cause the failure of the life support equipment or to significantly affect its safety or effectiveness is not recommended. Do not use this equipment in the presence of a flammable anesthetic mixture with air, oxygen or nitrous oxide.**

- You may experience uneven performance results if you connect a surge suppressor, line conditioner or UPS system to the output of the Inverter.

### Operation Warnings

- Your Inverter does not require routine maintenance. Do not open the device for any reason. There are no user-serviceable parts inside.
- Potentially lethal voltages exist within the Inverter as long as the battery is connected. During any service work, the battery should therefore be disconnected.
- Do not connect or disconnect batteries while the Inverter is operating. Dangerous arcing may result.

# Feature Identification

- 1 AC Outlets:** 3 NEMA 5-15R outlets allow you to connect equipment that you would normally plug into a utility outlet.
  - 2 Illuminated ON/OFF Switch:** When you set the switch to the ON position, the Inverter provides AC power by converting DC power from the connected battery. Set the switch to the OFF position to shut down the Inverter and conserve the battery's charge when you are not using connected equipment. Also set the switch to the OFF position to reset the Inverter if it has shut down due to low battery or overload. See the *Operation* section for more information.
  - 3 Cooling Fan:** This fan regulates the internal temperature of the Inverter and prolongs service life.
  - 4 DC Power Terminals:** These positive and negative terminals connect to the battery via user-supplied cabling. See the *Battery Connection* section for instructions.
  - 5 Main Ground Screw:** Connect to earth ground or to a vehicle or boat grounding system in order to properly ground the Inverter. See the *Battery Connection* section for instructions.
- Low Battery Alarm (not shown):** An internal circuit automatically detects low battery voltage and shuts down the Inverter to preserve your vehicle's battery. Turn the ON/OFF switch to the OFF position if the alarm sounds. See the *Operation* section for more information.
- Overload Alarm (not shown):** An internal circuit automatically detects overload conditions and shuts down the Inverter as a protective measure. Turn the ON/OFF switch to the OFF position if the alarm sounds. See the *Operation* section for more information.

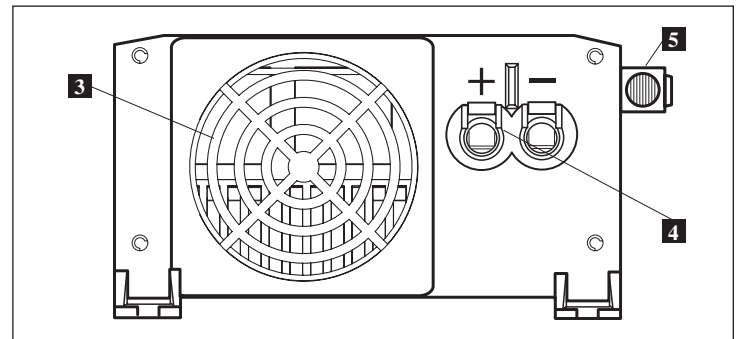
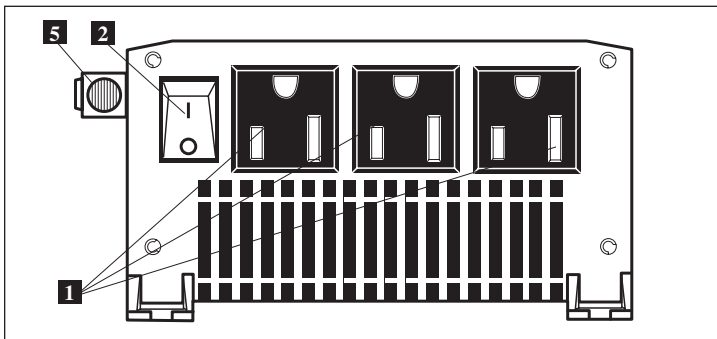

# Operation

## Operating Modes

After mounting and connecting your Inverter according to the instructions in this manual, use the illuminated ON/OFF switch to choose the Inverter's operating mode.

**ON:** When you set the switch to the ON position, the Inverter provides AC power to connected equipment by converting DC power from your vehicle's battery.

**OFF:** Set the switch to the OFF position to shut down the Inverter completely, preventing it from drawing power from your vehicle's battery. Also set the switch to the OFF position to reset the Inverter if it has shut down due to low battery or overload.

**Note:** After the unit has been turned OFF, wait at least 10 seconds before turning the unit back ON. The unit will not function without this wait period.

## Resetting the Inverter

The inverter may shut down and cease supplying AC power under certain conditions in order to protect itself, the battery and connected equipment. Follow these instructions to restore normal operation:

- Low Battery Alarm Reset:** If the Inverter has shut down due to low battery, (1) set the ON/OFF switch to the OFF position, (2) allow the Inverter to cool, (3) start the vehicle's engine to recharge the battery, (4) allow the battery to recharge completely and (5) set the ON/OFF switch to the ON position.
- Overload Alarm Reset:** If the Inverter has shut down due to overload, (1) set the ON/OFF switch to the OFF position, (2) allow the Inverter to cool, (3) remove the equipment that caused the overload, (4) confirm that any equipment now connected does not exceed the rated wattage of the Inverter and (5) set the ON/OFF switch to the ON position.

# Battery Selection

## Match Battery Amp-Hour Capacity to Your Application

Select a battery or system of batteries that will provide your Inverter with proper DC voltage and an adequate amp-hour capacity to power your application. Even though Tripp Lite Inverters are highly efficient at DC-to-AC inversion, their rated output capacities are limited by the total amp-hour capacity of connected batteries plus the output of an alternator when one is used.

# Battery Selection

## • STEP 1) Determine Total Wattage Required

Add the wattage ratings of all equipment you will connect to your Inverter. Wattage ratings are usually listed in equipment manuals or on nameplates. If your equipment is rated in amps, multiply that number times AC utility voltage to estimate watts. (Example: a drill requires 2.5 amps. 2.5 amps × 120 volts = 300 watts.)

*NOTE: Your Inverter will operate at higher efficiencies at about 75% - 80% of nameplate rating.*

## • STEP 2) Determine DC Battery Amps Required

Divide the total wattage required (from Step 1, above) by the battery voltage to determine the DC amps required and multiply by 1.2 to account for conversion losses.

## • STEP 3) Estimate Battery Amp-Hours Required

Multiply the DC amps required (from Step 2, above) by the number of hours you estimate you will operate your equipment exclusively from battery power before you have to recharge your batteries. This will give you a rough estimate of how many amp-hours of battery power (from one or several batteries) you should connect to your Inverter.

*NOTE: Battery amp-hour ratings are usually given for a 20-hour discharge rate. Actual amp-hour capacities are less when batteries are discharged at faster rates. For example, batteries discharged in 55 minutes provide only 50% of their listed amp-hour ratings, while batteries discharged in 9 minutes provide as little as 30% of their amp-hour ratings.*

## Example

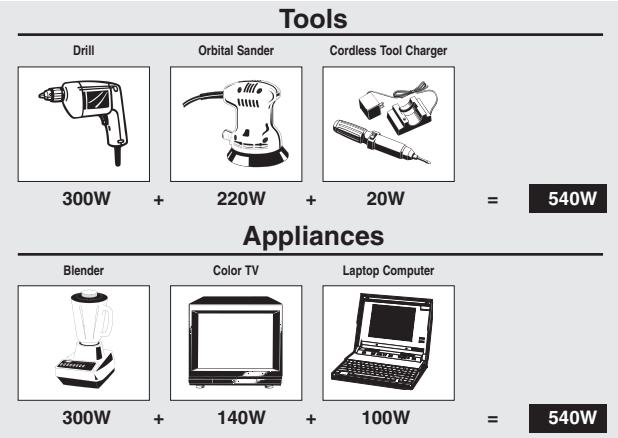

$$1.2 \times 540 \text{ watts} \div 12\text{V} = \mathbf{54 \text{ DC Amps}}$$

$$54 \text{ DC Amps} \times 5 \text{ Hrs. Runtime} = \mathbf{270 \text{ Amp-Hours}}$$

# Mounting



**WARNING! Mount your Inverter BEFORE DC battery connection. Failure to follow these instructions may lead to personal injury and/or damage to the Inverter and connected systems.**

Tripp Lite recommends that you permanently mount your Inverter in the configuration illustrated below. The Inverter features integral mounting brackets on the front and rear of the unit. The user must supply mounting hardware and is responsible for determining if hardware and mounting surface are adequate to support the weight of the unit.

Using the measurements as shown in the diagram install two user-supplied fasteners **1**, leaving the heads slightly raised. Slide the unit over the fasteners to engage the mounting bracket slots **2**. Tighten fasteners. Install two additional fasteners **3** over the remaining mounting bracket.

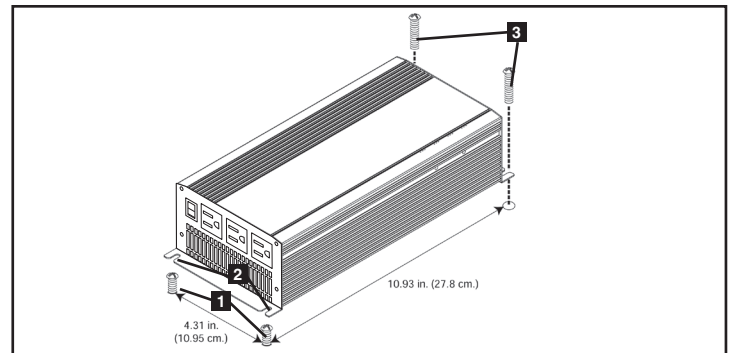

# Battery Connection

Connect your Inverter to your batteries using the following procedures:

• **Connect DC Wiring:** Though your Inverter is a high-efficiency converter of electricity, its rated output capacity is limited by the length and gauge of the cabling running from the battery to the unit. Use the shortest length and largest diameter cabling (maximum 4 AWG or 5 mm) to fit your Inverter's DC Input terminals. Shorter

and heavier gauge cabling reduces DC voltage drop and allows for maximum transfer of current. Your Inverter is capable of delivering peak wattage at up to 200% of its rated continuous wattage output for brief periods of time. Heavier gauge cabling should be used when continuously operating heavy draw equipment under these

# Battery Connection

conditions. Tighten your Inverter and battery terminals to approximately 3.5 Newton-meters of torque to create an efficient connection and to prevent excessive heating at this connection. Insufficient tightening of the terminals could void your warranty. **See Specifications for Recommended Cable Sizing.**

• **Connect Ground:** Using a 12-18 AWG (1-2 mm) wire, directly connect the Main Ground Screw to the vehicle's chassis or earth ground. See the Feature Identification section to locate the Main

Ground Screw. All installations must comply with national and local codes and ordinances.

• **Connect Fuse:** Tripp Lite recommends that you connect your Inverter's positive DC Terminal directly to a fuse(s) and fuse block(s) within 45 cm (18 inches) of the battery. The fuse's rating must equal or exceed the Minimum DC Fuse Rating listed in your Inverter's specifications. See Specifications for fuse recommendations. See diagrams below for proper fuse placement.



## WARNING!

- Failure to properly ground your Inverter to a vehicle's chassis or earth ground may result in a lethal electrical shock hazard.
- Never attempt to operate your Inverter by connecting it directly to output from an alternator rather than a battery or battery bank.
- Observe proper polarity with all DC connections.

## Vehicular Applications

Your Inverter's Nominal DC Input Voltage **must match** the voltage of your battery or batteries—12 Volts in most vehicular applications. It is possible to connect your Inverter to the main battery within your vehicle's electrical system. In many vehicular contexts, the Inverter will be connected to one or more dedicated auxiliary (house) batteries which are isolated from the drive system to prevent possible draining of the main battery.

- 1 12 Volt Alternator
- 2 Vehicle Battery Ground
- 3 12 Volt Main Battery
- 4 12 Volt Auxiliary (House) Battery
- 5 UL or CE Approved Fuses & Fuse Blocks (mounted within 18 inches [45 cm] of the battery)
- 6 Battery Isolator
- 7 Large Diameter Cabling, Maximum 4 AWG or 5 mm to Fit Terminals
- 8 12-18 AWG (1-2 mm) Ground Wire to Vehicle Frame or Earth Ground

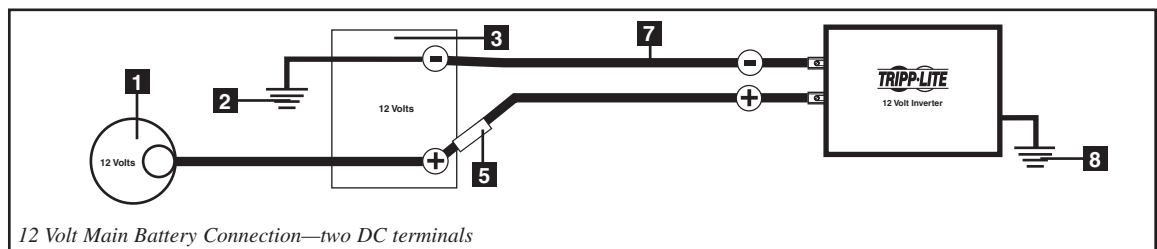

12 Volt Main Battery Connection—two DC terminals

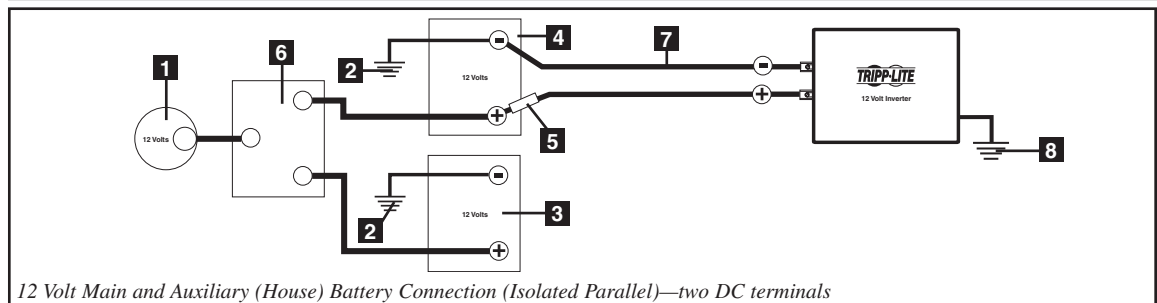

12 Volt Main and Auxiliary (House) Battery Connection (Isolated Parallel)—two DC terminals

## Service

Your Tripp Lite product is covered by the warranty described in this manual. A variety of Extended Warranty and On-Site Service Programs are also available from Tripp Lite. For more information on service, visit [www.tripplite.com/support](http://www.tripplite.com/support). Before returning your product for service, follow these steps:

1. Review the installation and operation procedures in this manual to insure that the service problem does not originate from a misreading of the instructions.
2. If the problem continues, do not contact or return the product to the dealer. Instead, visit [www.tripplite.com/support](http://www.tripplite.com/support).
3. If the problem requires service, visit [www.tripplite.com/support](http://www.tripplite.com/support) and click the Product Returns link. From here you can request a Returned Material Authorization (RMA) number, which is required for service. This simple on-line form will ask for your unit's model and serial numbers, along with other general purchaser information. The RMA number, along with shipping instructions will be emailed to you. Any damages (direct, indirect, special or consequential) to the product incurred during shipment to Tripp Lite or an authorized Tripp Lite service center is not covered under warranty. Products shipped to Tripp Lite or an authorized Tripp Lite service center must have transportation charges prepaid. Mark the RMA number on the outside of the package. If the product is within its warranty period, enclose a copy of your sales receipt. Return the product for service using an insured carrier to the address given to you when you request the RMA.

# Maintenance

Your Inverter requires no maintenance and contains no user-serviceable or replaceable parts, but should be kept dry at all times. Periodically check, clean and tighten all cable connections as necessary, both at the unit and at the battery.

# Troubleshooting

Please check the following before sending the Inverter in for service:

Symptom	Problem	Correction
Alarm sounds.	Low battery voltage (<10.5 V). Output overload.	Turn Inverter OFF and run engine to recharge vehicle battery. Turn Inverter OFF and remove overload by unplugging high-wattage devices. Load should not exceed your Inverter's maximum continuous output power (see Specifications).
Inverter does not turn ON when power switch is turned ON.	Automatic Inverter shutdown due to low battery voltage (<10V).	Turn Inverter OFF and run engine to recharge vehicle battery.
	Automatic Inverter shutdown due to output overload.	Turn Inverter OFF and remove overload by unplugging high-wattage devices. Load should not exceed your Inverter's maximum continuous output power (see Specifications).
	Blown fuse.	Replace fuse with standard automotive fuse of identical amperage (see Specifications).
Inverter is unable to power connected equipment.	Battery running low. Low battery voltage reduces Inverter power output.	Turn Inverter OFF and run engine to recharge vehicle battery.
	Connected equipment load exceeds Inverter's maximum continuous output power.	Turn Inverter OFF and remove overload by unplugging high-wattage devices. Load should not exceed your Inverter's maximum continuous output power (see Specifications).
Connected equipment experiences audio/video distortion.	Loose connections.	Check and secure all connections.
	Audio/video interference.	Reposition equipment antennas and Inverter.

# Specifications

<b>Model:</b>	<b>PV700HF</b>
Output Power (Maximum Continuous Watts)*:	700
Output Power (Peak Watts)**:	1400
Input Voltage (DC):	12V nominal (10-15V)
Output Voltage (AC)/Frequency:	120V / 60 Hz. nominal
Output Waveform:	PWM Sine Wave
Low Battery Voltage Alarm (Volts):	10.5V
Low Battery Voltage Shutdown (Volts):	10V
AC Outlets:	3 (NEMA 5-15R)
Circuit Protection (Minimum DC Fuse Rating):	125-amp fuse (external)
Minimum Battery Cable Size:	6 AWG (4 mm)
Maximum Battery Cable Size:	4 AWG (5 mm)
Ground Cable Size:	12-18 AWG (1-2 mm)
Housing Material:	Extruded Aluminum

\* Maximum output power (continuous or peak) only available when vehicle battery is properly charged. Run vehicle engine often to maintain proper charge. \*\* Peak Output Power is instantaneous.

## Typical Runtimes Before Battery Recharge

Although you can operate your Inverter with your vehicle engine off, best results are usually attained with the engine running. Since the Inverter converts electrical energy (and doesn't produce it), the Inverter's performance is relative to the condition of your vehicle's electrical system (battery, alternator and wiring). If other loads (air conditioner, heater, lights, etc.) are also using power, you may get less runtime.

	With Typical Compact Vehicle (4 cylinder) Battery, Alternator & Wiring	With Typical Mid-Size Vehicle (6 cylinder) Battery, Alternator & Wiring	With Typical Full-Size Vehicle (8 cylinder) Battery, Alternator & Wiring
<b>Model: PV700HF</b>			
1/2 Load (engine ON)	continuous	continuous	continuous
Full Load* (engine ON)	1-2 hours	2-4 hours	continuous
1/2 Load (engine OFF)	not recommended	1 hours	2 hours
Full Load* (engine OFF)	not recommended	not recommended	1 hour

NOTE: You can maximize output power by following one or more of these steps: (1) connect multiple batteries to the Inverter; (2) keep batteries fully charged by running the vehicle's engine often; (3) install the Inverter as close to the batteries as possible; (4) connect the heaviest gauge cable possible to the Inverter's DC terminals; (5) use the Inverter in a vehicle with a heavy-duty alternator; (6) run the vehicle's engine at higher RPMs.

### Battery Wiring Recommendations

For maximum efficiency, keep battery wires as short as possible. For very short runs, 6 AWG (4 mm) wiring may be adequate; for longer runs 4 AWG (5 mm) wiring is recommended. Acceptable output power is directly dependent on wire length: the shorter the wiring, the better the performance.

# Limited Warranty and Warranty Registration

Tripp Lite warrants its Inverters to be free from defects in materials and workmanship for a period of 1 year from the date of initial purchase. Tripp Lite's obligation under this warranty is limited to repairing or replacing (at its sole option) any such defective products. To obtain service under this warranty you must obtain a Returned Material Authorization (RMA) number from Tripp Lite or an authorized Tripp Lite service center. Products must be returned to Tripp Lite or an authorized Tripp Lite service center with transportation charges prepaid and must be accompanied by a brief description of the problem encountered and proof of date and place of purchase.

This warranty does not apply to equipment which has been damaged by accident, negligence or misapplication or has been altered or modified in any way, including opening of the unit's casing for any reason. This warranty applies only to the original purchaser who must have properly registered the product within 10 days of purchase.

EXCEPT AS PROVIDED HEREIN, TRIPP LITE MAKES NO WARRANTIES, EXPRESS OR IMPLIED, INCLUDING WARRANTIES OF MERCHANTABILITY AND FITNESS FOR A PARTICULAR PURPOSE. Some states do not permit limitation or exclusion of implied warranties; therefore, the aforesaid limitation(s) or exclusion(s) may not apply to the purchaser.

EXCEPT AS PROVIDED ABOVE, IN NO EVENT WILL TRIPP LITE BE LIABLE FOR DIRECT, INDIRECT, SPECIAL, INCIDENTAL OR CONSEQUENTIAL DAMAGES ARISING OUT OF THE USE OF THIS PRODUCT, EVEN IF ADVISED OF THE POSSIBILITY OF SUCH DAMAGE. Specifically, Tripp Lite is not liable for any costs, such as lost profits or revenue, loss of equipment, loss of use of equipment, loss of software, loss of data, costs of substitutes, claims by third parties, or otherwise.

## Warranty Registration

Visit [www.tripplite.com/warranty](http://www.tripplite.com/warranty) today to register the warranty for your new Tripp Lite product. You'll be automatically entered into a drawing for a chance to win a FREE Tripp Lite product!\*

\* No purchase necessary. Void where prohibited. Some restrictions apply. See website for details.

## Regulatory Compliance Identification Numbers

For the purpose of regulatory compliance certifications and identification, your Tripp Lite product has been assigned a unique series number. The series number can be found on the product nameplate label, along with all required approval markings and information. When requesting compliance information for this product, always refer to the series number. The series number should not be confused with the marking name or model number of the product.

Tripp Lite follows a policy of continuous improvement. Product specifications are subject to change without notice.



1111 W. 35th Street, Chicago, IL 60609 USA  
[www.tripplite.com/support](http://www.tripplite.com/support)